

SRT26H-C6

SHANTUI
VALUE THAT WORKS

Официальный дилер

BEL-DOZER

ROLLER
SERIES

| | |
|------------------|-----------------|
| ENGINE MODEL | WEICHAI WP4.6N |
| GROSS POWER | 147kW @ 2000rpm |
| OPERATING WEIGHT | 26000kg |

LET'S MAKE

CONSTRUCTION EASIER



ООО «ТПК Белдозер»:







тел./факс: +375 17 555-33-33;
моб.т.: +375 25 770-10-70;
e-mail: info@beldozer.by
Сайт: SHANTUI.BY



Сервисный центр:

Минский р-н, р-н пос. Колодищи,
тел.: +375 17 285 74 33 (66, 99);
Факс: +375 17 517-00-37

SRT26H-C6 TECHNICAL PARAMETERS

ROLLER SERIES

| | | |
|--|------------------------------|-----------------------------------|
|  | ENGINE | SRT26H-C6 |
| | Model | Weichai WP4.6N |
| | Number of Cylinders | 4 |
| | Type | 4-cycle, Water-cooled |
| | Aspiration | Turbocharged |
| | Bore x Stroke | 108x125mm |
| | Displacement | 4.58L |
| | Gross Power | 147kW @ 2000rpm |
| | Max. Torque | 820N.m @ 1400-1600rpm |
| | Emission | Tier 3 |
| | Air Cleaner | Dry type |
|  | POWER TRAIN | SRT26H-C6 |
| | Type | Hydraulic Power, Rear-wheel Drive |
| | Pump | Plunge Pump |
| | Motor | Plunge Motor |
| | Max. grade ability | 22% |
|  | STEERING | SRT26H-C6 |
| | Type | Hydraulic |
| | Steering Angle | ±30° |
| | Min. Turning Radius | 8330mm |
|  | BRAKES | SRT26H-C6 |
| | Service Brake | Hydraulic Brake |
| | Parking Brake | Hydraulic Brake |
| | Emergency Brake | Hydraulic Brake |
|  | TIRE | SRT26H-C6 |
| | Type | 11.0-20.0 |
| | Number of Tires | Front 5, Rear 6 |
| | Wheel Track Overlap | 50mm |
| | Working Width | 2750mm |
| | Tire Distance | 490mm |
| | Ground Pressure | 200-420KPa |
| | Swing Distance of Front Tire | ±50mm |
|  | SPEED | SRT26H-C6 |
| | Forward,1 | 0-6km/h |
| | Forward,2 | 0-13km/h |
| | Reverse,1 | 0-6km/h |
| | Reverse,2 | 0-13km/h |
|  | CAPACITIES | SRT26H-C6 |
| | Fuel Tank | 170L |
| | Hydraulic Oil Tank | 60L |
| | Coolant | 22L |
| | Engine Crank Case | 13L |
| | Sprinkle Water Tank | 630L |

| | | |
|---|--------------------------|------------------|
|  | ELECTRICAL SYSTEM | SRT26H-C6 |
| | Battery | 2X12V |
| | Alternator | 28V, 80A |
| | Starter Motor | 24V, 4.5kW |
|  | WEIGHT | SRT26H-C6 |
| | Max. Operating Weight | 26000kg |
| | Metal ballast | 9400kg |
| | Average Wheel Load | 2360kg |

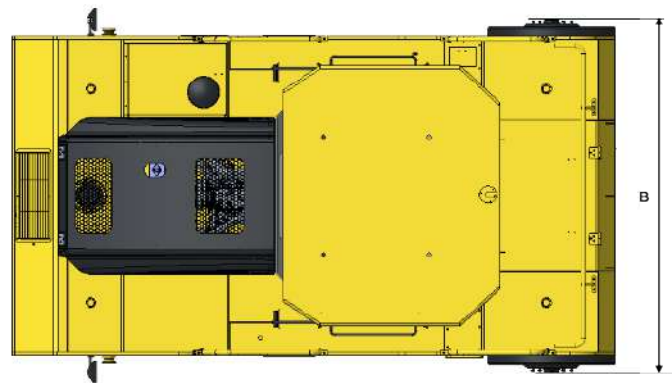
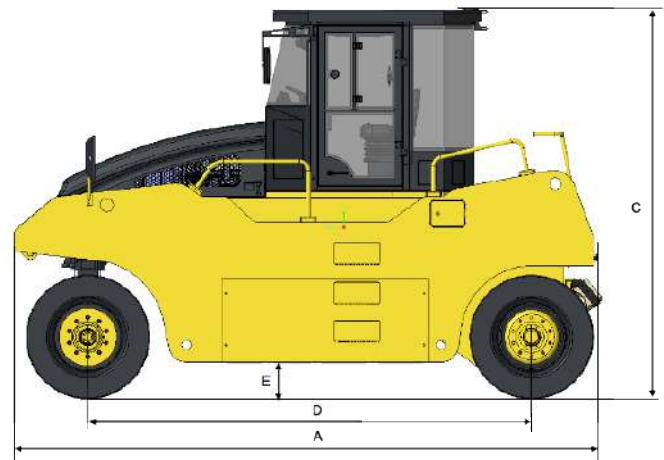

| | | |
|---|-------------------|------------------|
|  | DIMENSIONS | SRT26H-C6 |
| | A | 4920mm |
| | B | 2915mm |
| | C | 3410mm |
| | D | 3840mm |
| | E | 375mm |